

Operation manual for modular HAMEG laboratory setup

The HAMEG HM-8000 Module System extended with the HM-207 oscilloscope is a complete measurement setup for basic electronic measurements. The individual devices (modules) can be placed a mainframe which is capable of housing two devices. The mainframe only serves for mechanical fixing and supplying power for the devices. In the following the specifications of the HM 8040 triple power supply, the HM 8011 digital multimeter and the HM 8021 frequency-meter (counter) will be discussed.

Knowing the specifications and operating instructions of the devices is necessary to execute a successful measurement and prevent damaging the setup.

I. HM 8040-2 TRIPLE POWER SUPPLY

After putting the module into the mainframe it is ready for usage. The power supply has two variable (0-20 V) and one fixed 5 V output. The variable output can be loaded up to 0.5 A, the fix one up to 1 A.

On Fig. 1 **4** and **10** are the variable outputs, the left connection is the negative, the right one is the positive connection. The output voltage can be tuned by **3**, **6** and **9**, **12** turn knob. The **3** and **12** knobs are for coarse setting, the **6** and **9** are for fine tuning. The set voltage values are shown on the display, **1** if the **2** and **14** switches are in out position. The output current can be limited with the **5** and **11** screws in the 10-500 mA range.

The **7** output is the fixed 5 V (the left connector is the negative one), this output is not indicated on the display and the maximal output current is 1 A. The voltage can be fine tuned in the 4.5-5.5 V range with the screw above the connectors.

The output appears on the connectors only if the **8** switch is pressed in (output on), which is indicated by a rectangle shaped LED.

If the **2** and **14** switches are in the *in* position, the output current is indicated on the display. If the output is limited by the set current limit (maximum 0.5 A), it is indicated by the triangle shaped LED.

The device has so called floating outputs, so connecting more in series higher potential difference can be used. This is shown on Fig. 2.

II. HM 8011 DIGITAL MULTIMETER

The device is capable to measure DC and AC voltage and current and resistance. The measured quantity can be chosen by the **2**, **4** and **6** buttons (see Fig. 3). It measures in DC if the **8** button is in *out* position and measures in AC if it is *in*. The range knob, **10** should set

to a range which is higher than the measured quantity itself. Measuring voltage or resistance the cables should be connected to **5** and **7** connector, while currents up to 2 A can be measured between connectors **3** and **5**, and currents up to 10 A can be measured between **11** and **5**. The display has 4 1/2 digits, which means the maximal displayable number is 19999, and the decimal point is automatically set according to the range.

The operation of the device is explained by showing how to measure a given quantity.

A general rule is that at first all setting have to set, and just after that connect the cables.

A. Measuring DC voltage

Lets assume that the voltage drop on resistance R of Fig. 4 has to measured (and it is below 5 V).

- Choose the measured quantity (voltage) by pressing button **6**.
- Button **8** should be in out position (since DC quantity is measured).
- The range knob, **10** should be in 20 V position, so the highest measurable voltage is 19.999 V.
- One end of the resistor should be connected to the voltage input **7**, the other can to the COMMON input **5**.
- Read the value indicated by the display (e.g. 2.456), which is volts now. If the number positive (it has no sign), than the more positive end of the resistor is connected to the voltage input and the negative to the COM input. In case of negative value, the potential relations are the opposite.

If the measurable quantity is higher than the range, the display shows 0 and flashes (just like in all other modes).

The voltage-meter has to be connected parallel to the circuit element.

B. Measuring AC voltage

The difference compared to the DC case, that button **8** should be in in position. The measured quantity is always positive, and means the true effective (RMS) value.

C. Measuring DC current

Now the problem is to measure the current in the upper branch of Fig. 5 (it is around 50 mA)

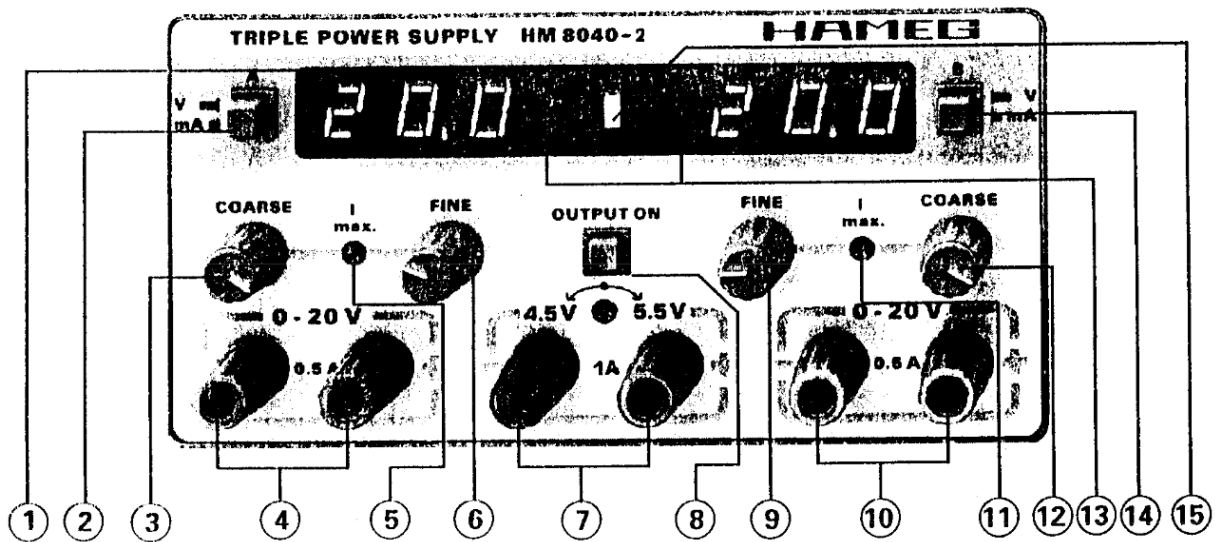

FIG. 1.

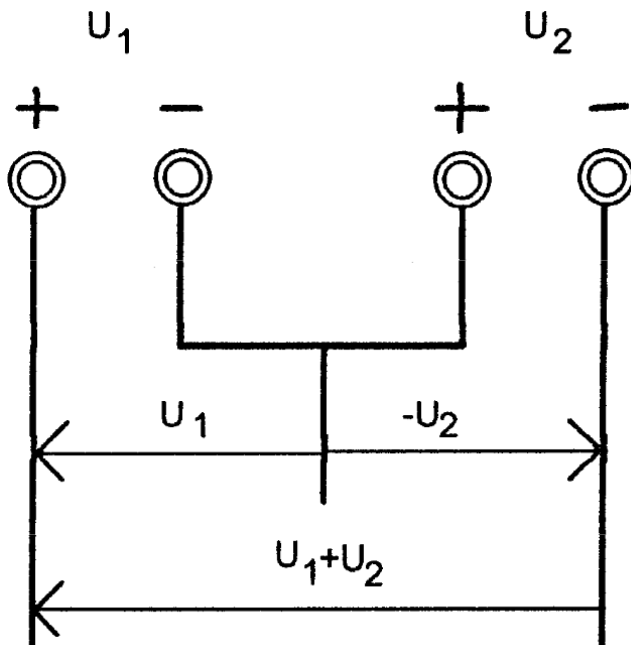

FIG. 2.

- Choose the current mode by pressing button 2.
- Button 8 should be in out position (DC current).
- Range knob 10 should be in the 200 range (the highest measurable current is 200 mA).
- Cut the upper branch of the circuit, and connect the multimeter in series by connecting to the mA port (3) and the COM port (5).

- Read the measured quantity. If it is positive the current flows into the device via port 3 and out of it on port 5, and vice versa.

The current meter always have to be connected in series! Measuring the current of a power supply is unreasonable and forbidden!

D. Measuring AC current

In case of AC current the button 8 should be in position, the other setting are same as in DC.

E. Measuring resistance

To properly measure the resistance, it is crucial to understand the functioning of the multimeter. The resistor has to be connected to the 5 and 7 connectors, then the multimeter emits a current signal on port 7, which going through the resistor goes back to the multimeter via port 5. Measuring the voltage drop on the resistor, induced the current, the device calculates value of the resistor and indicates it on the display. It follows that only resistor out of electric circuits can be measured this way, since in a circuit the emitted current goes through no only the examined resistor, but the whole circuit, and the total resistance of the circuit between the two given points will be measured.

Other important requisite that no power supply can be connected to the measured resistor, since in this case the multimeter measures the sum of the voltage of the external power supply and the voltage induced by the probe current, and an incorrect value would be shown

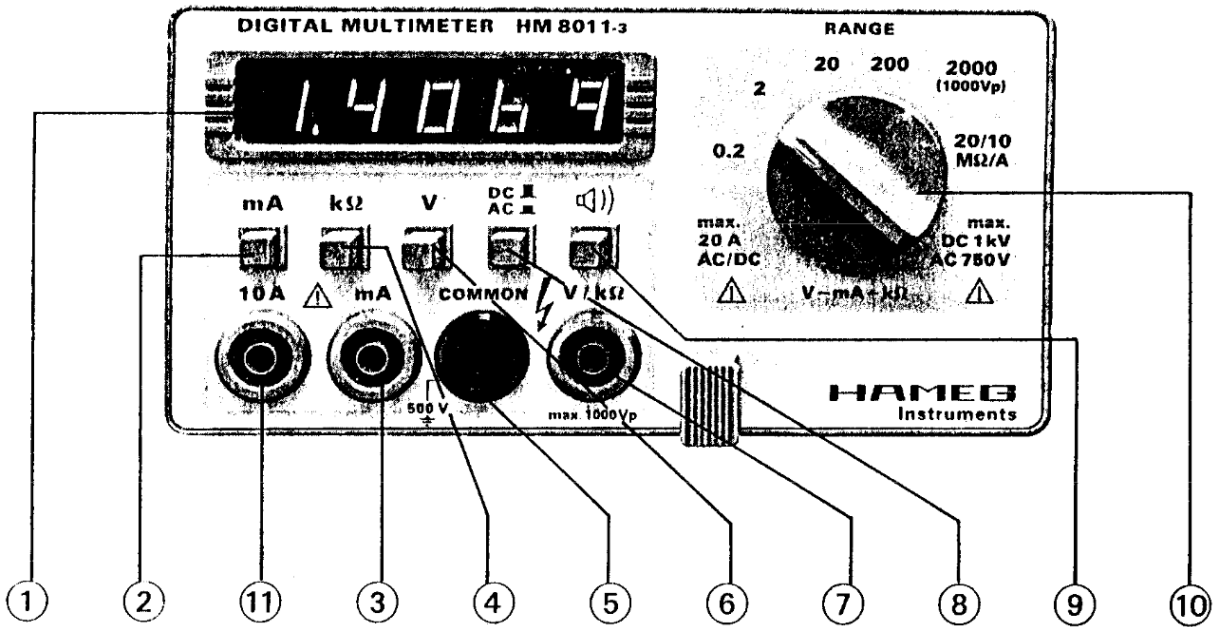

FIG. 3.

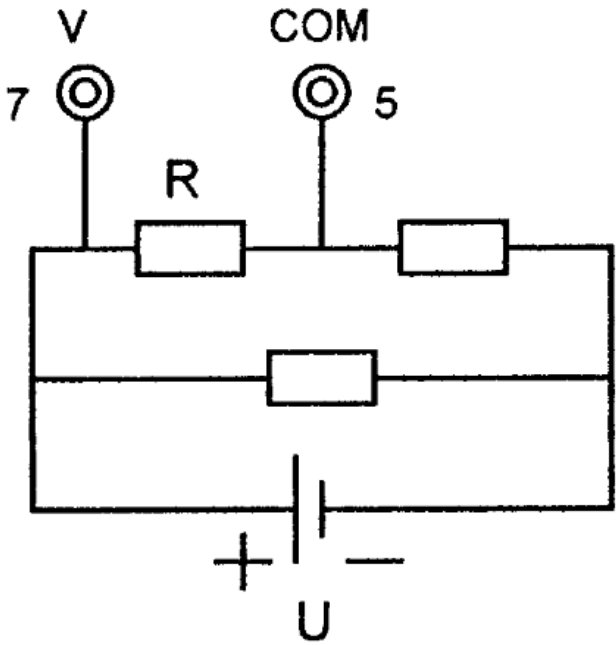

FIG. 4.

- Choose the resistance mode by pressing button 4.
- Set the range knob to the suitable position.

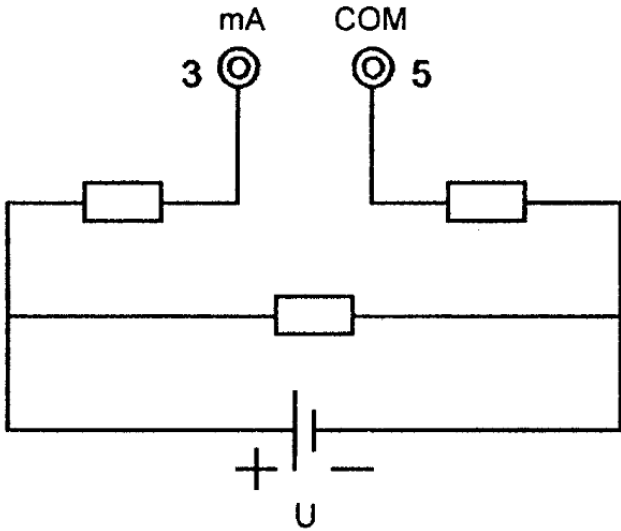

FIG. 5.

on the display. Furthermore the current induced by the external power supply can damage the multimeter.

The steps for measuring the resistance are the following:

- Connect the resistor, which is not connected to an electric circuit and absent of any voltage, to the 5 and 7 connectors.
- Read the measured value.