

# Fizika 1i

Rezgések

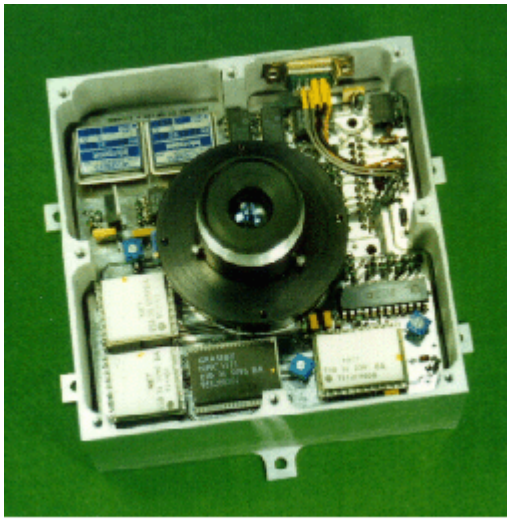

## **LDS V8-440**

### **Sine, random and shock testing**

Max force = 66 kN

Max acceleration = 140g

Max velocity = 1.78 m/s

Max displacement = 63mm P to P

May payload (including moving mass) =  
700Kg



# Rezgések

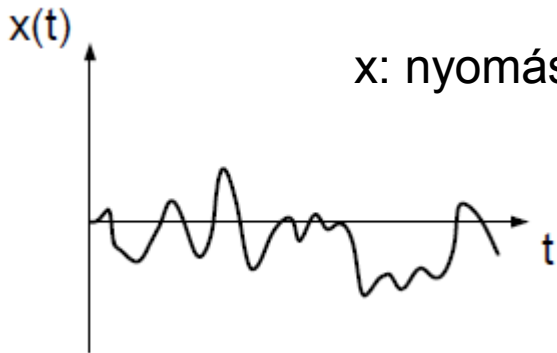

x: nyomás, pozíció, hőmérséklet,...



Fizikai folyamatok (JELEK)

Időbeli lefolyás szerint:

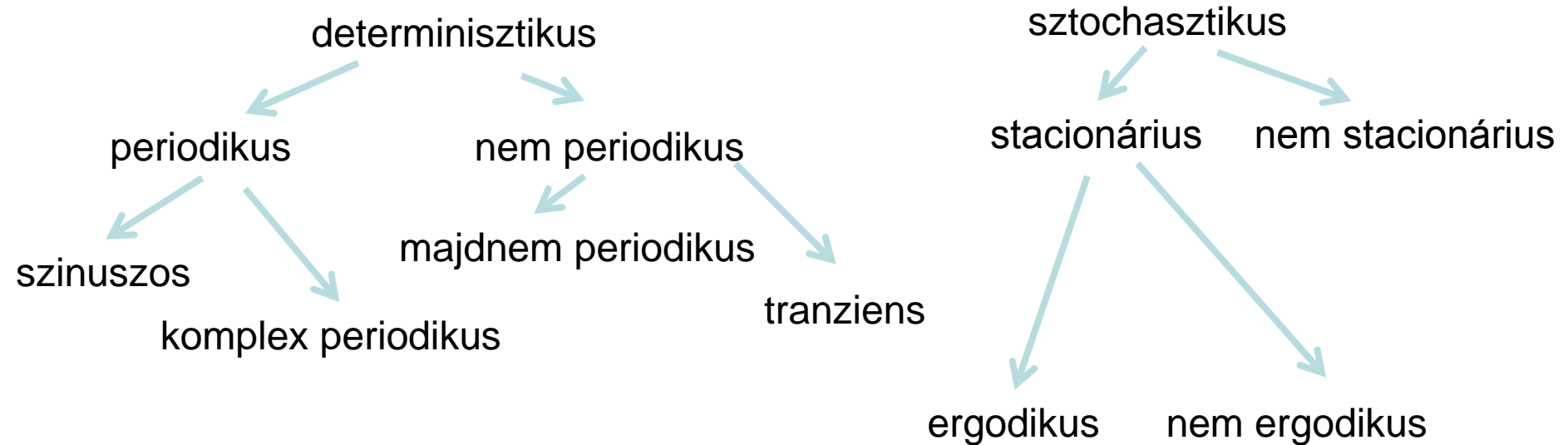

pl: periodikus jel megkülönböztetése sztochasztikus jel jelenlétében

Jellemzés (valószínűség számítási alapok) :

- valószínűség sűrűség függvény
- autokorrelációs függvény
- teljesítmény sűrűség függvény
- spektrum

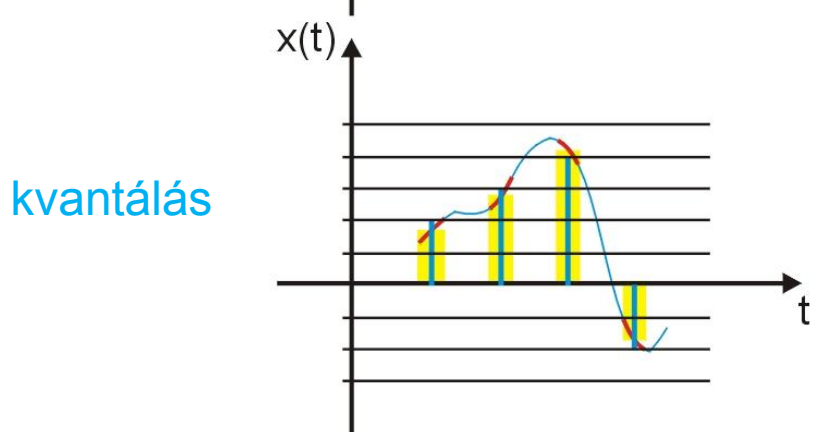
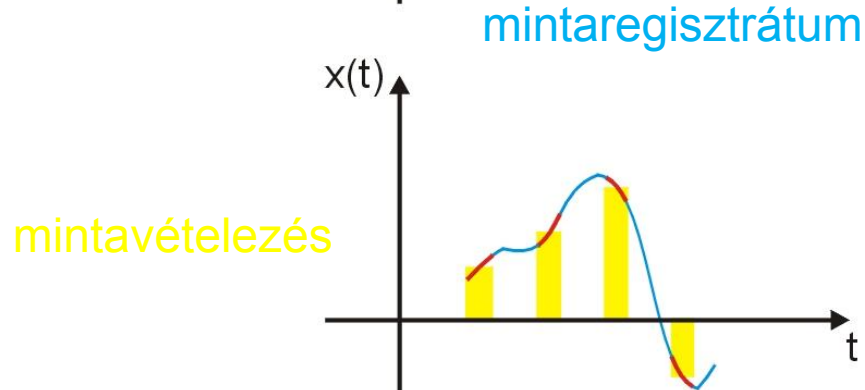
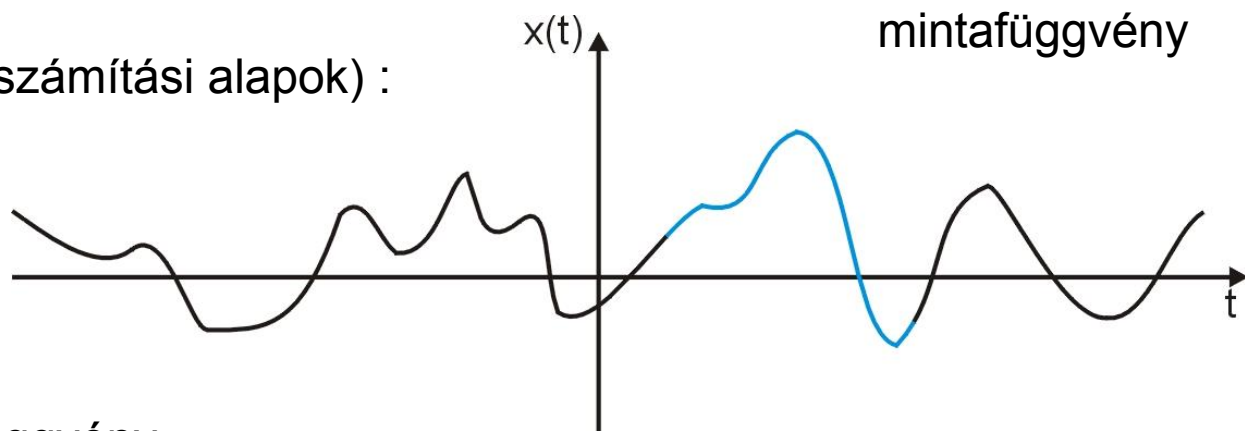

# Rezgőmozgás

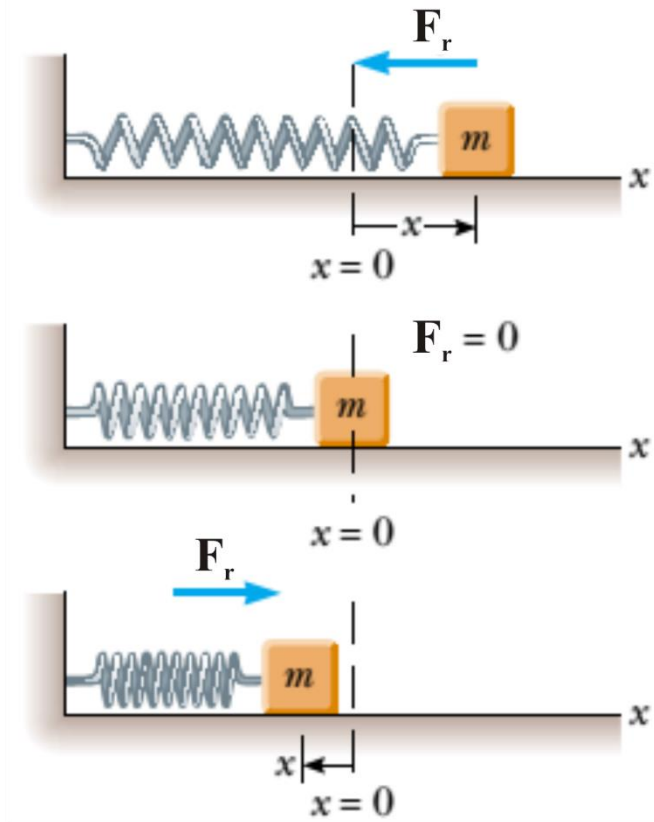

$F_r$ : rugóerő

$$F_r = -Dx$$

$$F_e = F_r$$

Newton 2. törv.:  $F_e = ma$

$$ma = -Dx \rightarrow a = -\frac{D}{m}x \longrightarrow$$

$$\ddot{x} = -\frac{D}{m}x$$

mozgásegyenlet

Megoldása:  $x(t) = A \sin(\omega t + \varphi)$

## Harmonikus rezgőmozgás:

$$x(t) = A \sin(\omega t + \varphi)$$

$A$  : amplitúdó

$\omega$  : körfrekvencia

$\varphi$  : kezdőfázis

$$\omega = \sqrt{\frac{D}{m}}$$

$$\omega = \frac{2\pi}{T} \Rightarrow T = 2\pi \sqrt{\frac{m}{D}}$$

A rezgőmozgást végző test sebessége:

$$v(t) = A \omega \cos(\omega t + \varphi)$$

Maximális sebesség:

$$v_{\max} = A \omega$$

A rezgőmozgást végző test gyorsulása:

$$a(t) = -A \omega^2 \sin(\omega t + \varphi)$$

Maximális gyorsulás:

$$a_{\max} = A \omega^2$$

Kezdeti feltételek:  $x(t=0) = x_0$  és  $v(t=0) = v_0 \Rightarrow A = \dots$  és  $\varphi = \dots$

elmozdulás

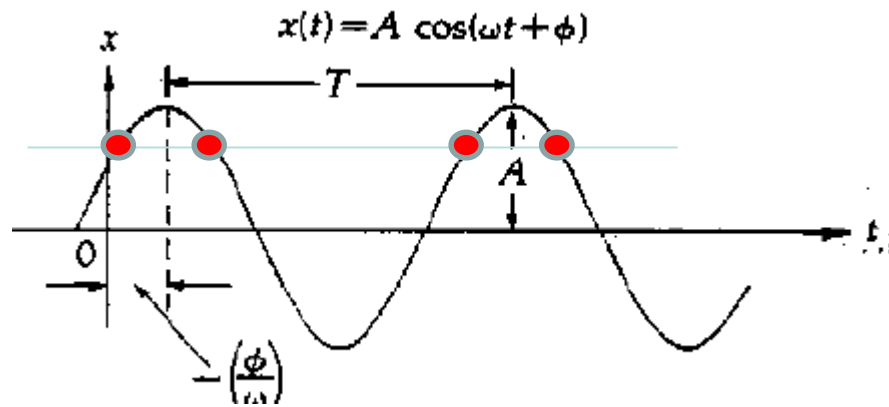

sebesség

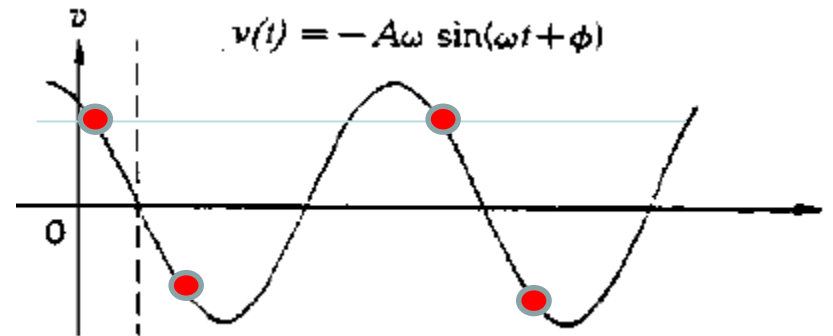

gyorsulás

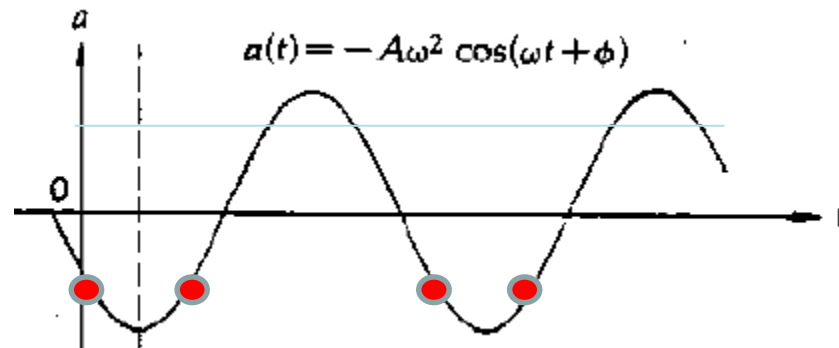

## ***A rezgő test energiája:***

$$E = E_k + E_{pot}$$

$$E = \frac{1}{2}mv^2 + \frac{1}{2}Dx^2$$

$$E = \frac{1}{2}mv^2 + \frac{1}{2}Dx^2 = \frac{1}{2}m(A\omega)^2\cos^2(\omega t + \varphi) + \frac{1}{2}DA^2\sin^2(\omega t + \varphi)$$

$$E = \frac{1}{2}mv_{max}^2 + \frac{1}{2}DA^2$$



# A rezgő test potenciális energiája:

(A rugóban tárolt energiája)

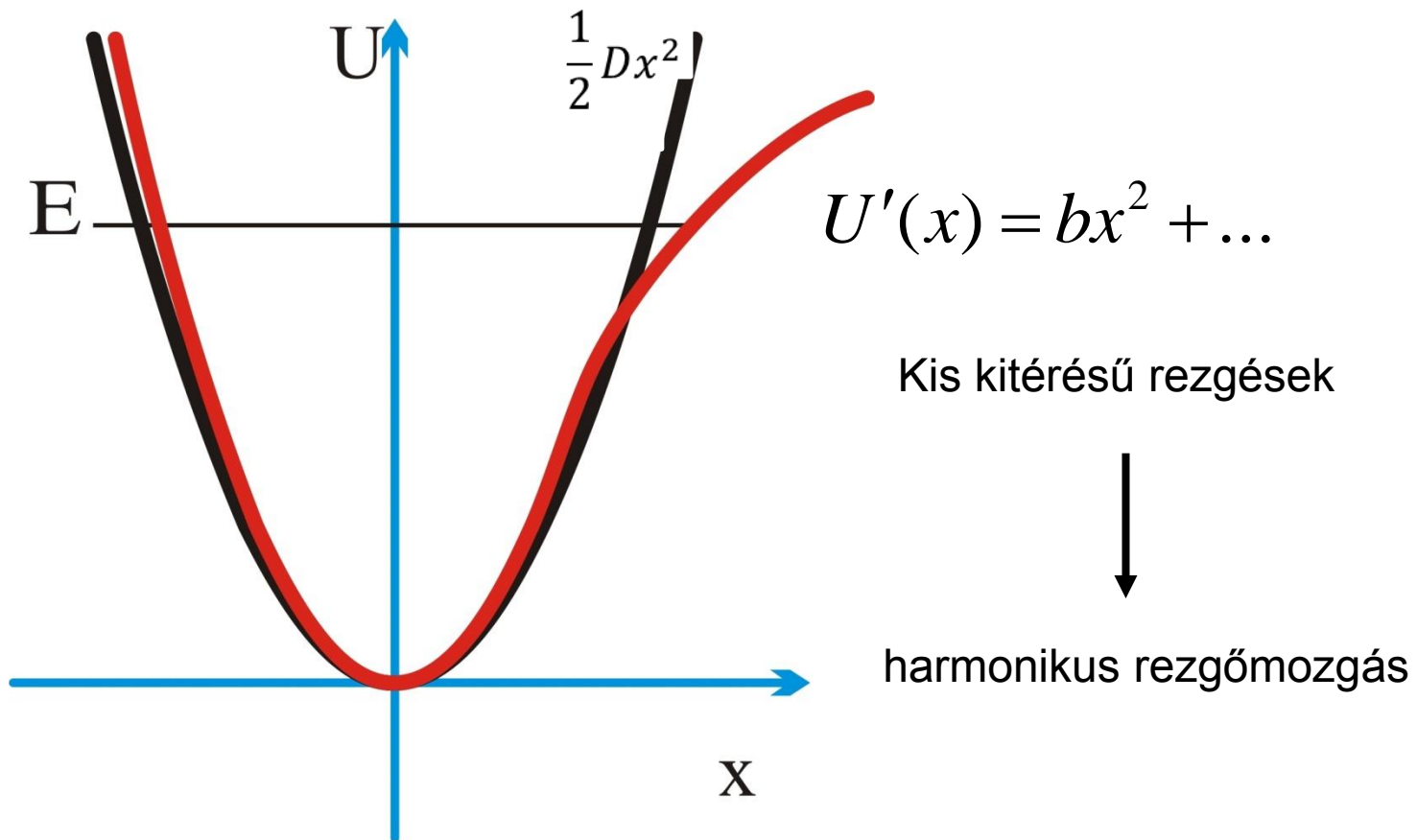

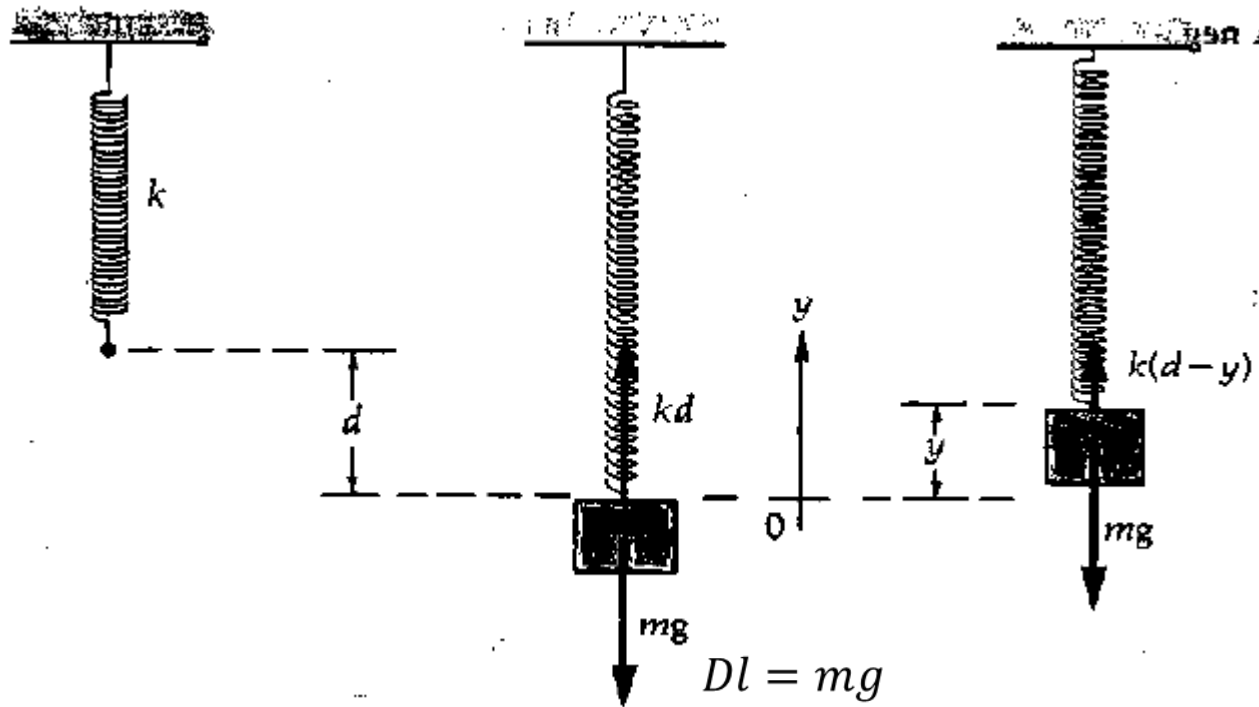

**Mozgásegyenlet:**  $ma = D(l - y) - mg$

$$ma = -Dy$$

**Megoldás:**  $y(t) = A \sin(\omega t + \varphi)$

# Fizikai inga

$$|\vec{M}| = mgs \cdot \sin \varphi \quad M = \Theta \beta$$

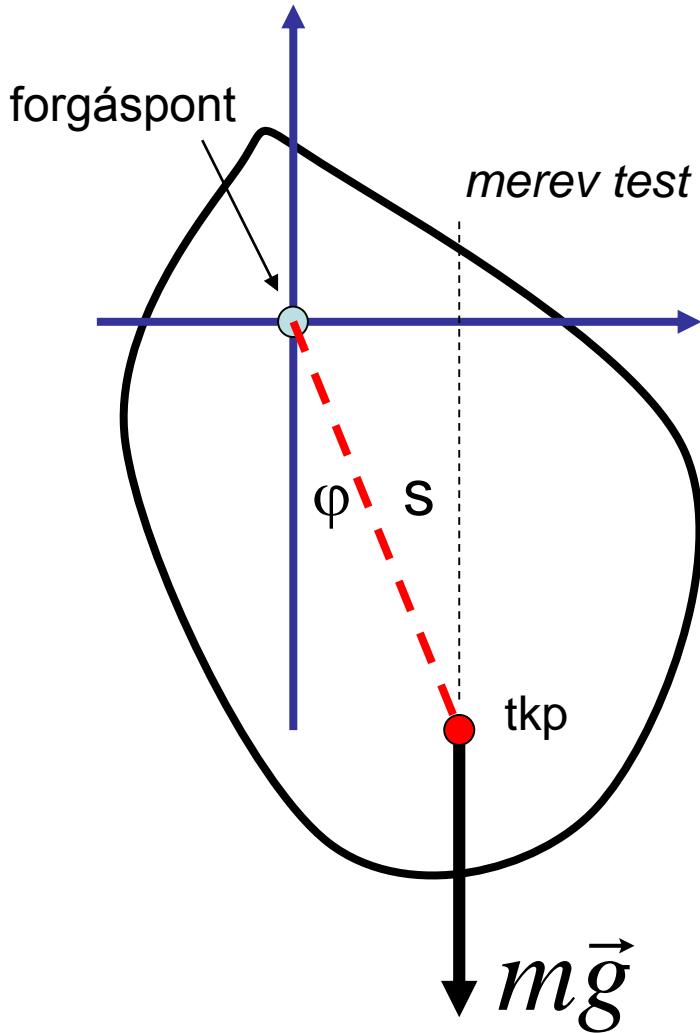

$$\Theta \beta = -mgs \cdot \sin \varphi$$

$$/ \varphi \ll 1 \text{ rad} \Rightarrow \sin \varphi \approx \varphi /$$

$$\Theta \beta = -mgs \varphi$$

$$\ddot{\varphi} = -\frac{mgs}{\Theta} \varphi$$

$$\ddot{x} = -\frac{D}{m} x \quad \omega = \sqrt{\frac{D}{m}} \quad \omega = \frac{2\pi}{T}$$

$$\omega = \sqrt{\frac{mgs}{\Theta}} \Rightarrow T = 2\pi \sqrt{\frac{\Theta}{mgs}}$$

## Matematikai inga

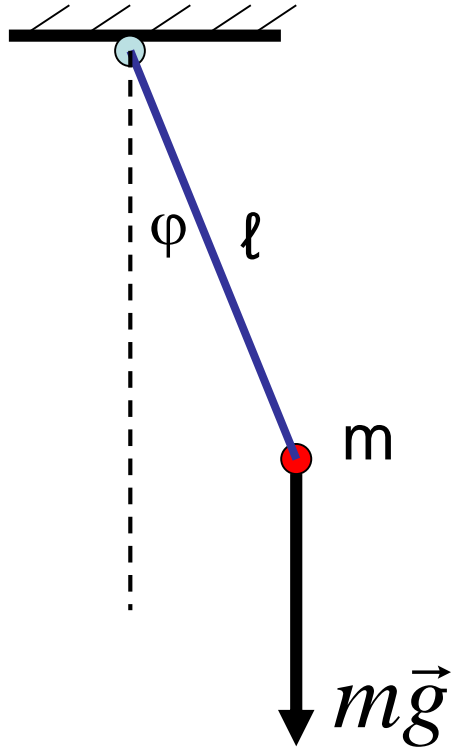

$$\Theta = m\ell^2$$

$$s = \ell$$

$$T = 2\pi \sqrt{\frac{\Theta}{mgs}}$$

$$T = 2\pi \sqrt{\frac{\ell}{g}}$$

$$/ \varphi \ll 1 \text{ rad} /$$

## Torziós inga

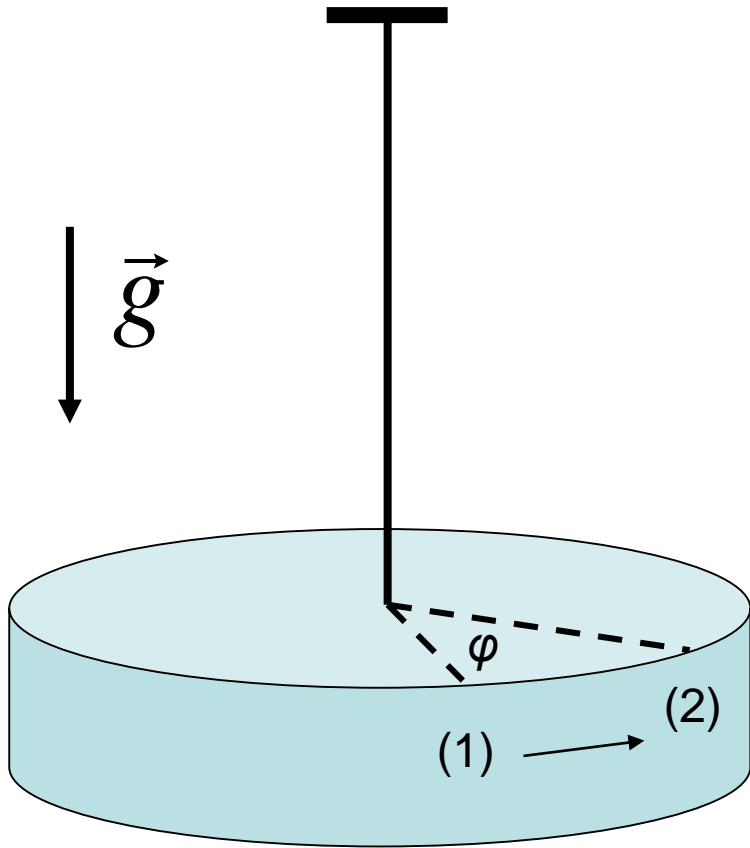

$$\omega = \frac{2\pi}{T}$$

$$M = -\kappa\varphi$$

$$M = \Theta\beta$$

$$\Theta\beta = -\kappa\varphi$$

$$\ddot{\varphi} = -\frac{\kappa}{\Theta}\varphi$$

$$\omega = \sqrt{\frac{\kappa}{\Theta}} \Rightarrow T = 2\pi\sqrt{\frac{\Theta}{\kappa}}$$

## Csillapított rezgőmozgás

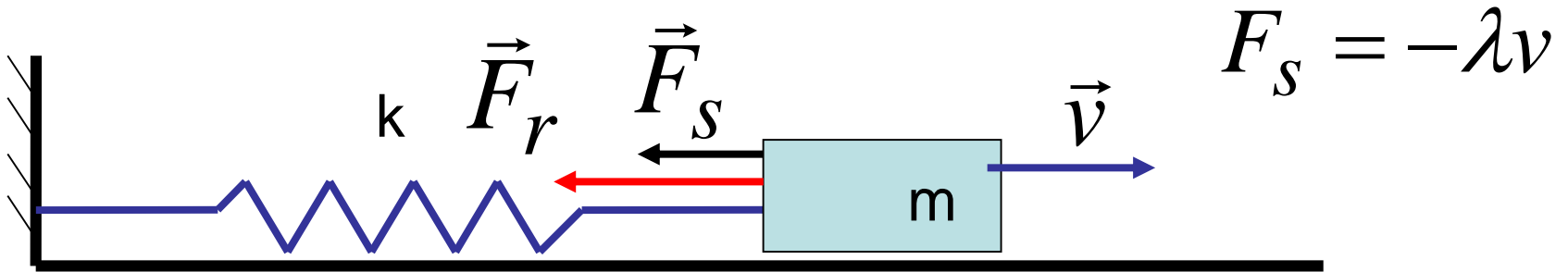

$$ma = -Dx - \lambda v \longrightarrow m\ddot{x} = -Dx - \lambda\dot{x}$$

$$\beta = \frac{\lambda}{2m} \quad \text{és} \quad \frac{D}{m} = \omega_0^2 \quad \Rightarrow \quad \ddot{x} + 2\beta\dot{x} + \omega_0^2 x = 0$$

Mozgástörvény:  $x(t) = Ae^{-\beta t} \sin(\omega t + \varphi)$

$$\omega_0 > \beta \quad !!! \quad \omega = \sqrt{\omega_0^2 - \beta^2}$$

$$x(t) = A e^{-\beta t} \sin(\omega t + \varphi)$$

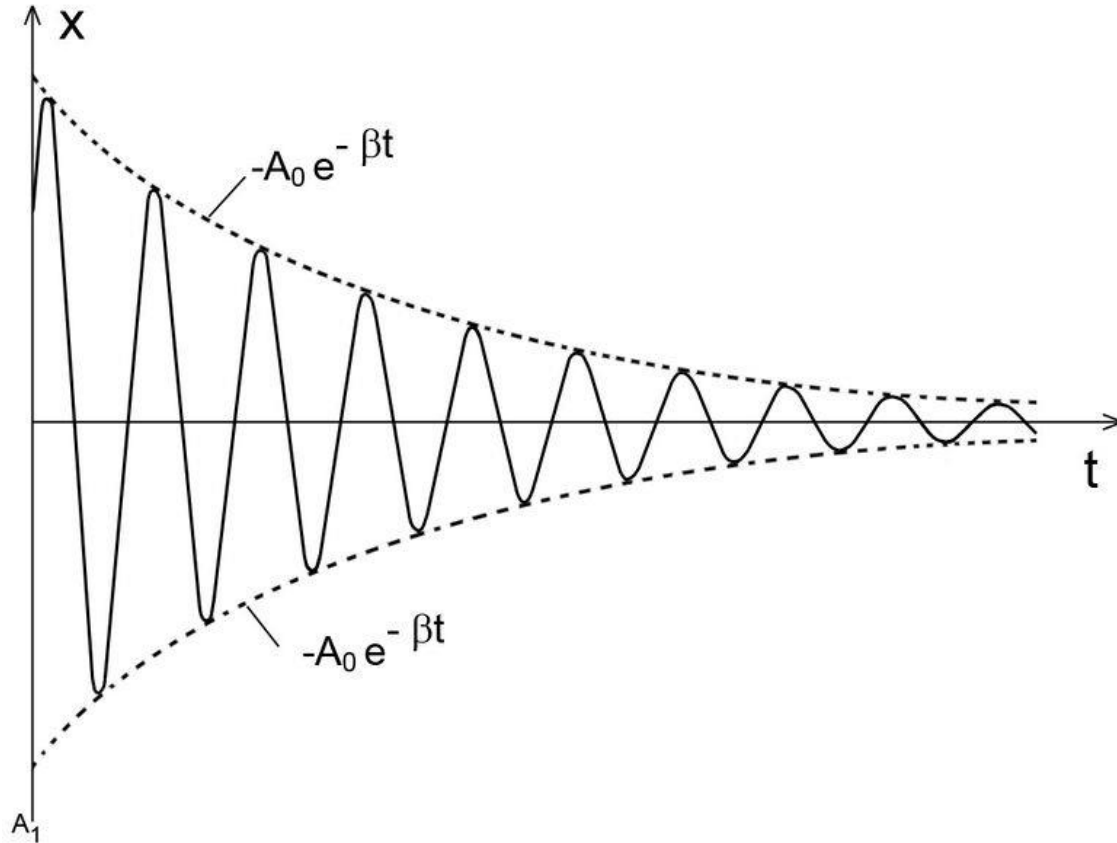

## Aperiódikus határeset

$$\ddot{x} + 2\beta\dot{x} + \omega_o^2 x = 0 \quad \omega_o = \beta \quad !!!$$

$$x(t) = e^{-\beta t} (ct + a)$$

Kezdeti feltételek:  $x(t=0) = x_o$  és  $v(t=0) = v_o \Rightarrow c = \dots$  és  $a = \dots$

Pl.:  $x_o = 0$  és  $v(t=0) = v_o$

$$x(t) = v_o t e^{-\beta t}$$

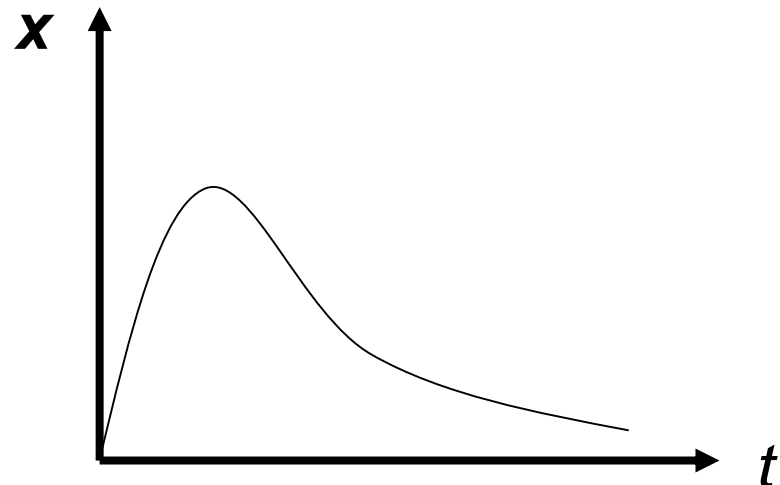



## Túlcsillapított rezgés

$$\omega_o < \beta \quad !!!$$

$$\ddot{x} + 2\beta\dot{x} + \omega_o^2 x = 0$$

$$x(t) = ae^{\lambda_1 t} + be^{\lambda_2 t}$$

$$\lambda_{1,2} = -\beta \pm \sqrt{\beta^2 - \omega_o^2} < 0$$

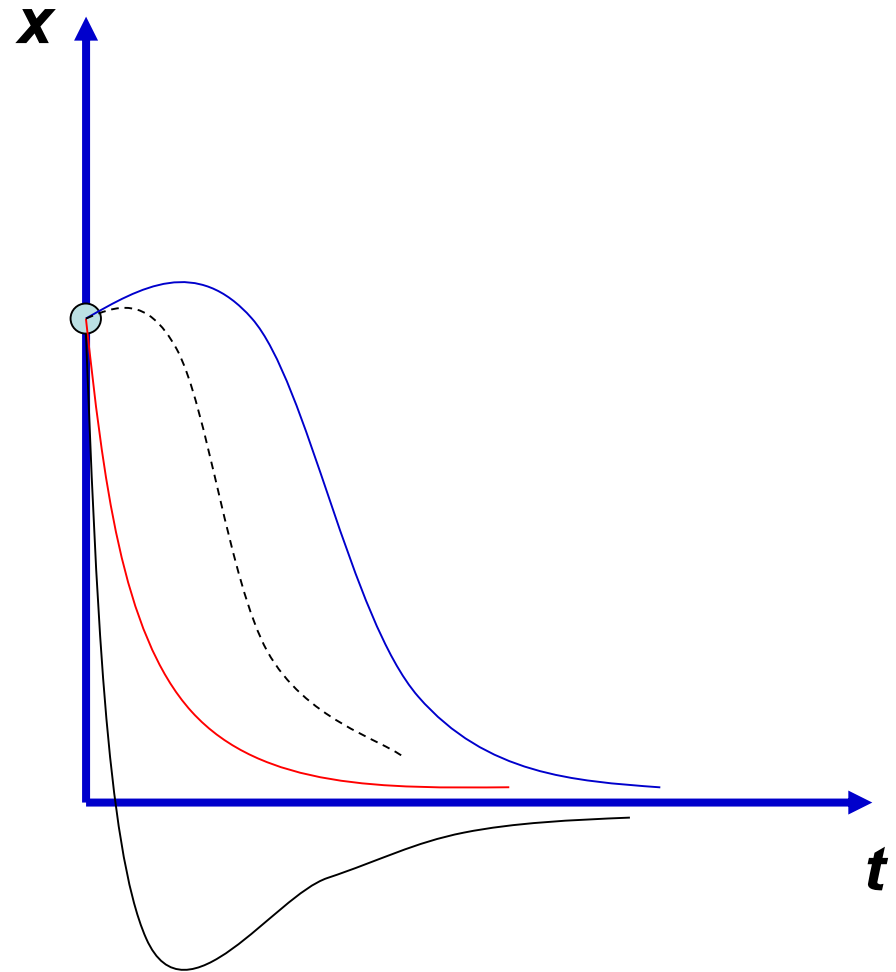

## Kényszerrezgés, rezonancia

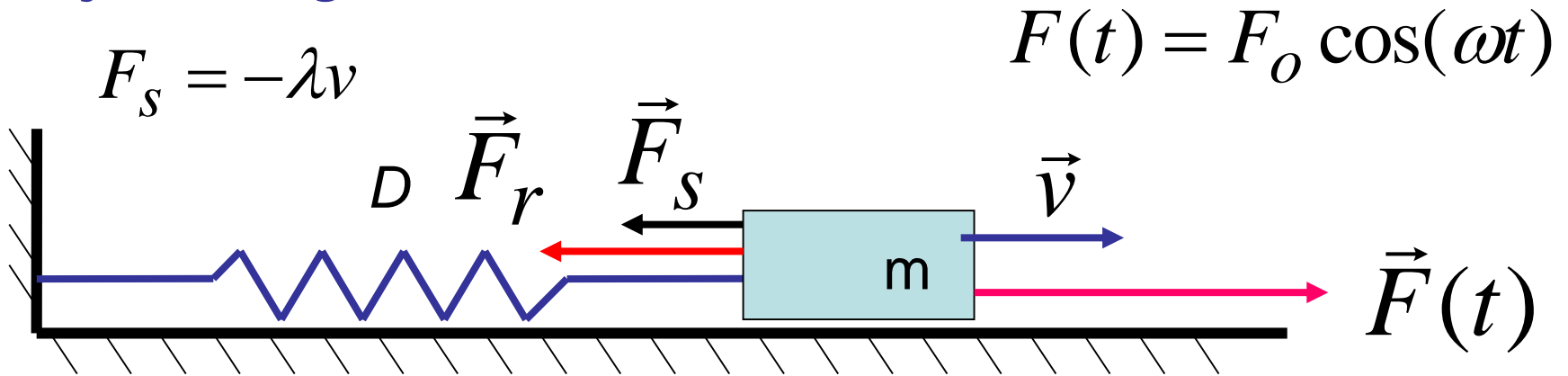

$$ma = -Dx - \lambda v + F_0 \cos(\omega t) \quad f_0 = \frac{F_0}{m}$$

$$\ddot{x} + 2\beta\dot{x} + \omega_0^2 x = f_0 \cos(\omega t)$$

$$x(t) = A \cos(\omega t - \varphi) + ae^{-\beta t} \sin(\sqrt{\omega_0^2 - \beta^2} t + \alpha)$$

$$A = \frac{f_0}{\sqrt{(\omega_0^2 - \omega^2)^2 + 4\beta^2 \omega^2}}$$

$$\operatorname{tg} \varphi = \frac{2\beta\omega}{\omega_0^2 - \omega^2}$$

## Az amplitúdó frekvenciafüggése:

$$A = \frac{f_o}{\sqrt{(\omega_o^2 - \omega^2)^2 + 4\beta^2\omega^2}}$$

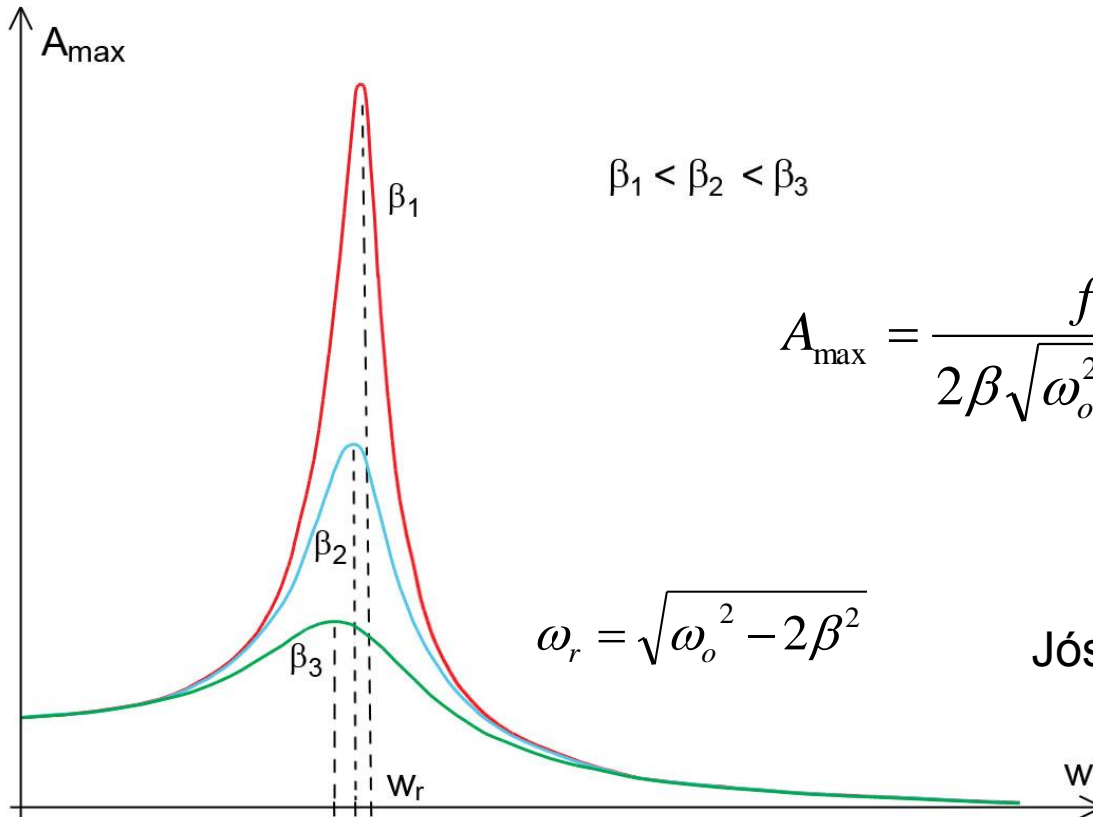

$$\beta_1 < \beta_2 < \beta_3$$

$$\omega_{\max} = \sqrt{\omega_o^2 - 2\beta^2}$$

$$A_{\max} = \frac{f_o}{2\beta\sqrt{\omega_o^2 - 2\beta^2}} \approx \frac{f_o}{2\beta\omega_o} \quad \text{ha } \beta \ll \omega_o$$

$$\omega_r = \sqrt{\omega_o^2 - 2\beta^2}$$

Jósági tényező:

$$Q = \frac{\omega_o}{2\beta}$$

## A fázis frekvenciafüggése:

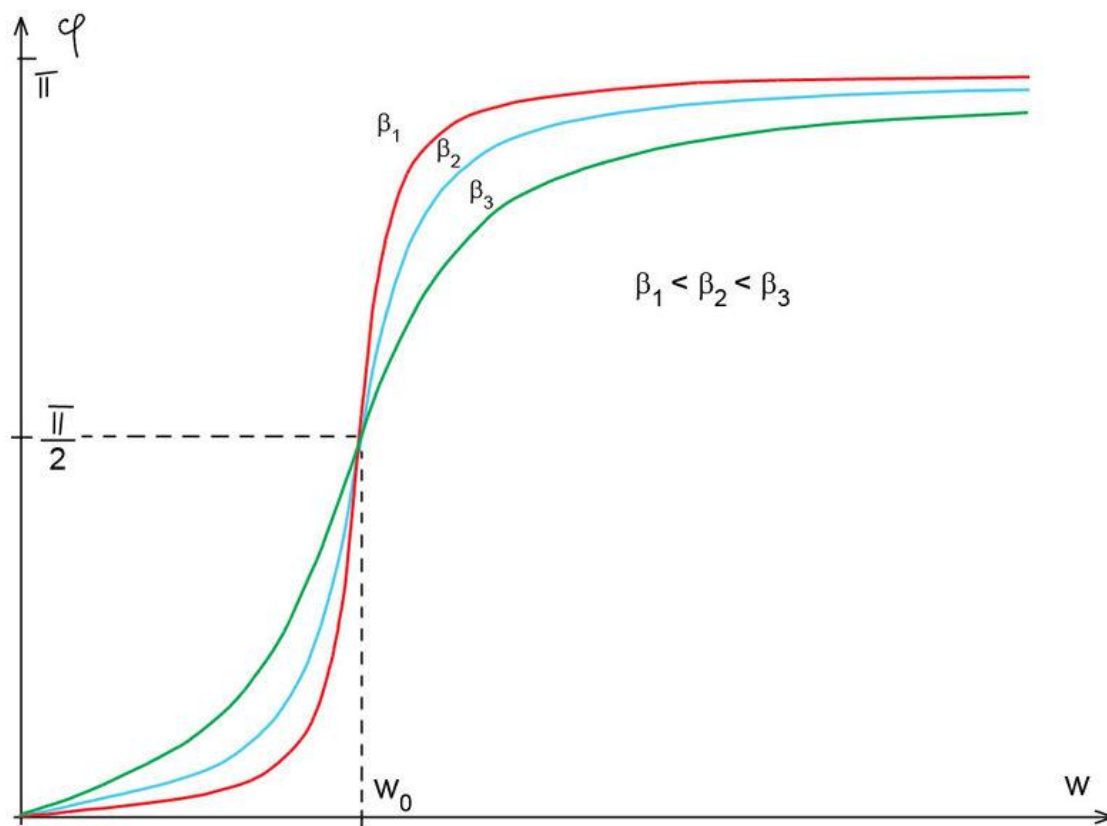

$$\operatorname{tg} \varphi = \frac{2\beta\omega}{\omega_0^2 - \omega^2}$$

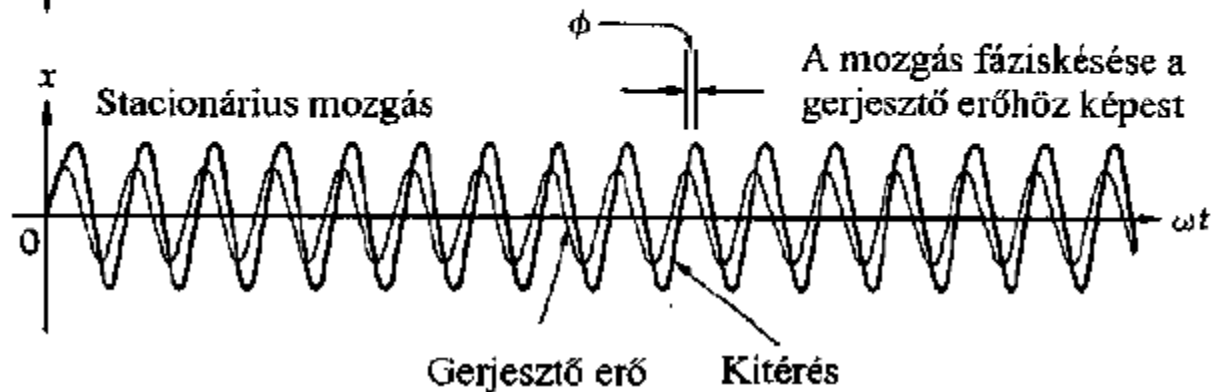
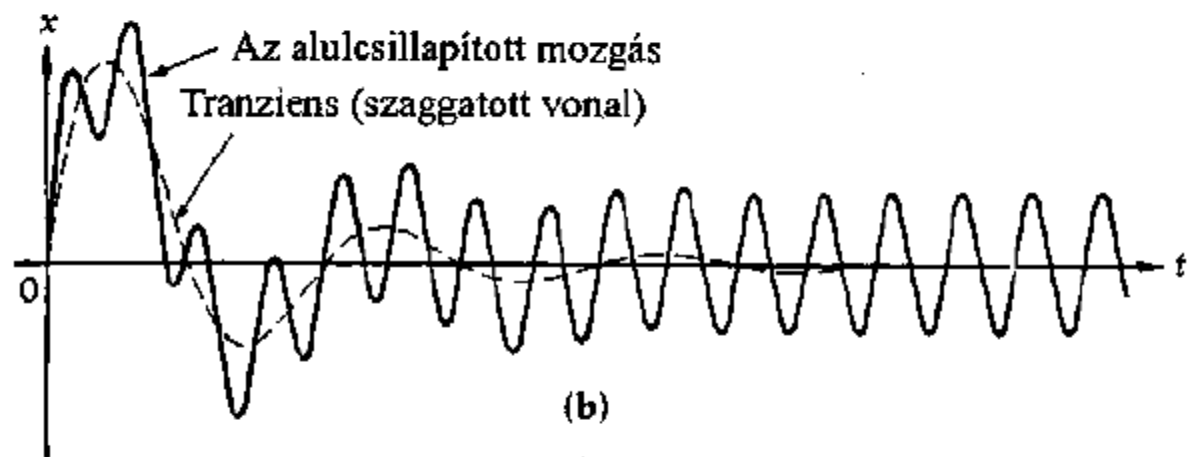
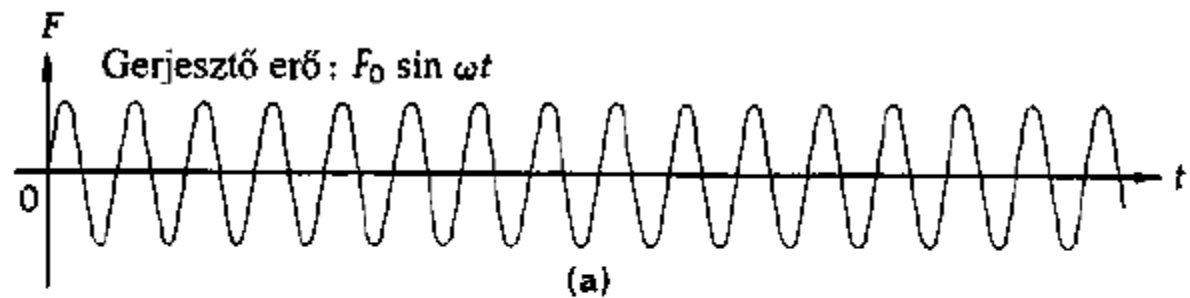

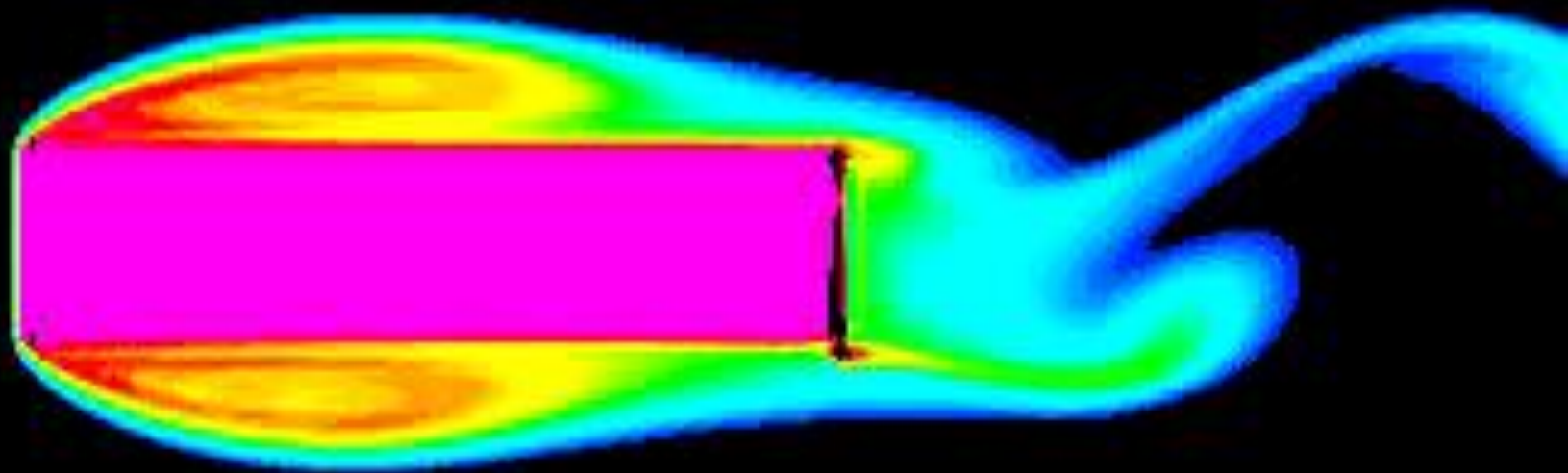
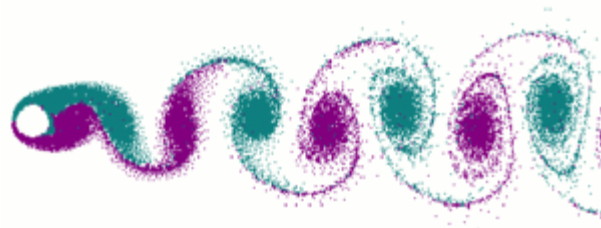

## ***Rezonanciakatasztrófa:***



## Dinamikus csillapítás:

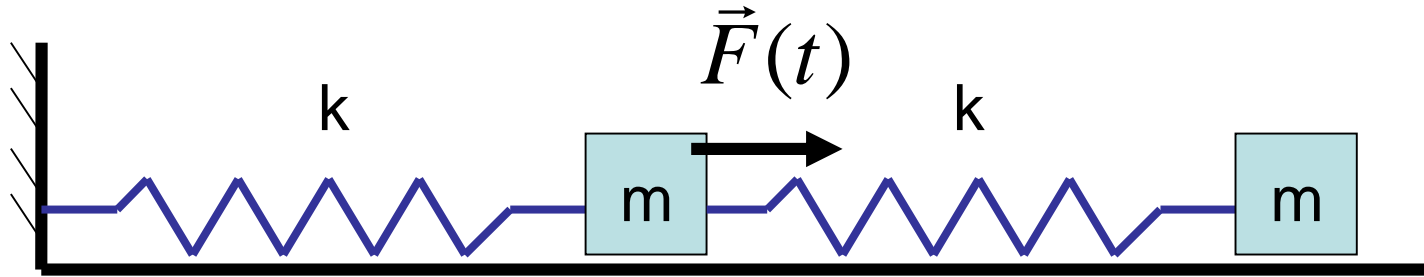

*Felhőkarcoló kilengésének csökkentése dinamikus csillapítással:*

